



Basic Web Base Training

P-3521 MFP

P-4020 MFP

P-3527w MFP

P-4025w MFP

P-4026iw MFP

Model's Basic Specifications



		P-4020 MFP	P-4025w MFP	P-4026iw MFP
Copy	Copy speed	40 A4 pages/min	40 A4 pages/min	40 A4 pages/min
	Copy resolution	600 x 600 dpi	600 x 600 dpi	600 x 600 dpi
	Greyscales	256	256	256
	Standard paper feed	350 (1 x 250 + 100 sheets)	350 (1 x 250 + 100 sheets)	350 (1 x 250 + 100 sheets)
	Optional paper feed	2 x 250 sheets	2 x 250 sheets	2 x 250 sheets
	Paper capacity, max	850 sheets	850 sheets	850 sheets
	Paper format	A6R-A4	A6R-A4	A6R-A4
	Original feeder	Standard (Duplex Scan)	Standard (Duplex Scan)	Standard (Duplex Scan)
	Duplex	Standard	Standard	Standard
	System memory	512 MB RAM (max 1,536 MB RAM)	512 MB RAM (max 1,536 MB RAM)	512 MB RAM (max 1,536 MB RAM)
Zoom	25%–400%	25%–400%	25%–400%	
Cabinet	Option: no. 78	Option: no. 78	Option: no. 78	
Print	Type	Integrated within the system	Integrated within the system	Integrated within the system
	Interfaces	10/100/1000BaseTX, USB 2.0, USB host, SD slot	10/100/1000BaseTX, USB 2.0, USB host, SD slot, Wi-Fi	10/100/1000BaseTX, USB 2.0, USB host, SD slot, Wi-Fi
	Operating systems	Windows XP, Vista, Windows 7/8/8.1/10, Server 2003/2008 R2/2012 R2/2016/2019, Linux, Mac ex OS 10.6	Windows XP, Vista, Windows 7/8/8.1/10, Server 2003/2008 R2/2012 R2/2016/2019, Linux, Mac ex OS 10.6	Windows XP, Vista, Windows 7/8/8.1/10, Server 2003/2008 R2/2012 R2/2016/2019, Linux, Mac ex OS 10.6
Emulations	PCL6 (5e, XL), KPDL 3 (PostScript 3 compatible), PRESCRIBE IIe, Line Printer, IBM Proprinter, Epson LQ-850, PDF 1.7, XPS, Open XPS	PCL6 (5e, XL), KPDL 3 (PostScript 3 compatible), PRESCRIBE IIe, Line Printer, IBM Proprinter, Epson LQ-850, PDF 1.7, XPS, Open XPS	PCL6 (5e, XL), KPDL 3 (PostScript 3 compatible), PRESCRIBE IIe, Line Printer, IBM Proprinter, Epson LQ-850, PDF 1.7, XPS, Open XPS	
Network	Interfaces	10/100/1000BaseTX	10/100/1000BaseTX	10/100/1000BaseTX
	Network protocols	TCP/IP, Net BEUI	TCP/IP, Net BEUI	TCP/IP, Net BEUI
	Operating systems	Windows XP, Vista, Windows 7/8/8.1/10, Server 2003/2008 R2/2012 R2	Windows XP, Vista, Windows 7/8/8.1/10, Server 2003/2008 R2/2012 R2	Windows XP, Vista, Windows 7/8/8.1/10, Server 2003/2008 R2/2012 R2
Scan	Scan type	CIS colour and b/w	CIS colour and b/w	CIS colour and b/w
	Scan resolution	200, 300, 400, 600 dpi	200, 300, 400, 600 dpi	200, 300, 400, 600 dpi
	Interfaces	10/100/1000BaseTX, USB 2.0	10/100/1000BaseTX, USB 2.0	10/100/1000BaseTX, USB 2.0
	Network protocols	TCP/IP	TCP/IP	TCP/IP
Fax	Originals	--	max A4	max A4
	Modem speed	--	33.6 kbps	33.6 kbps
	Compression method	--	JBIG, MMR, MR, MH	JBIG, MMR, MR, MH
	One-touch dial/abbr. dial	--	100/200	100/200

Operation Panel (TSI)

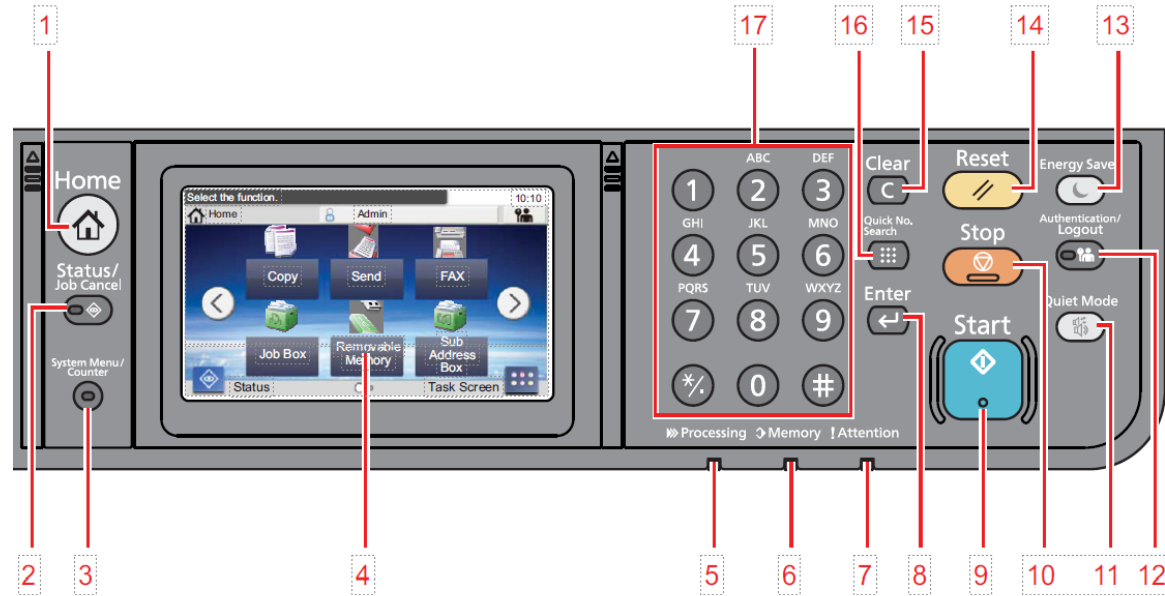

1. [Home] key: Displays the Home screen.
2. [Status/Job Cancel] key: Displays the Status/Job Cancel screen.
3. [System Menu/Counter] key: Displays the System Menu/Counter screen.
4. Touch panel: Displays icons for configuring machine settings.
5. [Processing] indicator: Blinks while printing or sending/receiving.
6. [Memory] indicator: Blinks while the machine is accessing the machine memory or fax memory.
7. [Attention] indicator: Lights or blinks when an error occurs and a job is stopped.
8. [Enter] key: Finalizes numeric key entry, and finalizes details during setting of functions. Operates linked with the on-screen [OK].
9. [Start] key: Starts copying and scanning operations and processing for setting operations.
10. [Stop] key: Cancels or pauses the job in progress.
11. [Quiet Mode] key: Lower print and scan speed for quiet processing.
12. [Authentication/Logout] key: Authenticates user switching, and exits the operation for the current user (i.e. log out).
13. [Energy Saver] key: Puts the machine into Sleep Mode. Recovers from Sleep if in Sleep Mode.
14. [Reset] key: Returns settings to their default states.
15. [Clear] key: Clears entered numbers and characters.
16. [Quick No. Search] key: Specifies registered information such as address numbers and user IDs by number.
17. Numeric keys: Enter numbers and symbols.

Operation Panel Keys (LCD)

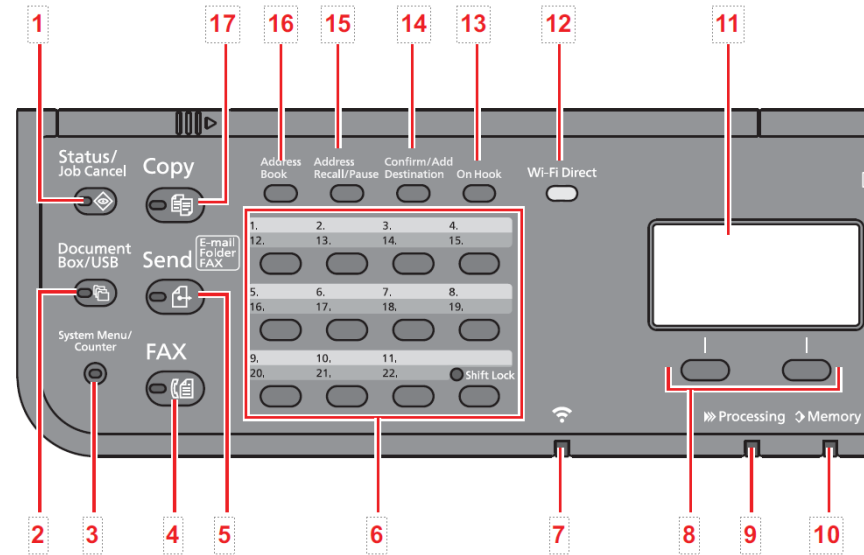

1. [Status/Job Cancel] key: Displays the Status/Job Cancel screen.
2. [Document Box/USB] key: Displays the Document Box/USB screen.
3. [System Menu/Counter] key: Displays the System Menu/Counter screen.
4. [FAX] key: Displays the FAX screen.
5. [Send] key: Displays the screen for sending. You can change it to display the Address Book screen.
6. One Touch keys: Recalls the destination registered for One Touch Keys.
7. [Wi-Fi] indicator : Blinks during Wi-Fi connection.
8. Select keys: Selects the menu displayed at the bottom of the message display.
9. [Processing] indicator: Blinks while printing or sending/receiving.
10. [Memory] indicator: Blinks while the machine is accessing the machine memory or fax memory.
11. Message display: Displays the setting menu, machine status, and error messages.
12. [Wi-Fi Direct] key: Set Wi-Fi Direct, and show information necessary for connection and the connection status.
13. [On Hook] key: Switches between on-hook and off-hook when manually sending a FAX.
14. [Confirm/Add Destination] key: Confirms the destination or adds a destination.
15. [Address Recall/Pause] key: Calls the previous destination. Also used to enter a pause when entering a FAX number.
16. [Address Book] key: Displays the Address Book screen.
17. [Copy] key: Displays the Copy screen.

Expansion Memory

The machine can perform the more multiple jobs simultaneously by adding more memories. You can increase the machine's memory up to 1,536 MB by plugging in the optional memory modules.

Precautions for Handling the Memory Modules

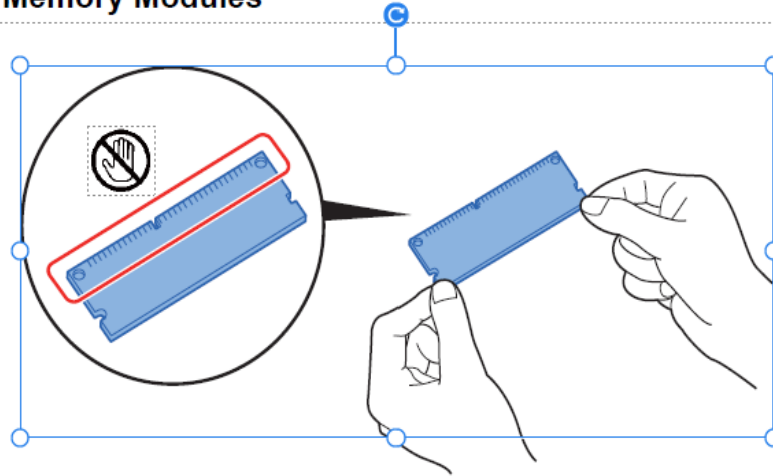

To protect electronic parts, discharge static electricity from your body by wearing an antistatic wrist strap, if possible, when you install the memory modules. If you do not have a wristband, touch a metal object to discharge static electricity before inserting the memory.

Installing the Memory Modules

1. Turn off the machine and disconnect the power cord and interface cable.
2. Remove the cover.

Installing Expansion Memory

1. Turn off the machine and disconnect the power cord and interface cable.
2. Remove the cover.

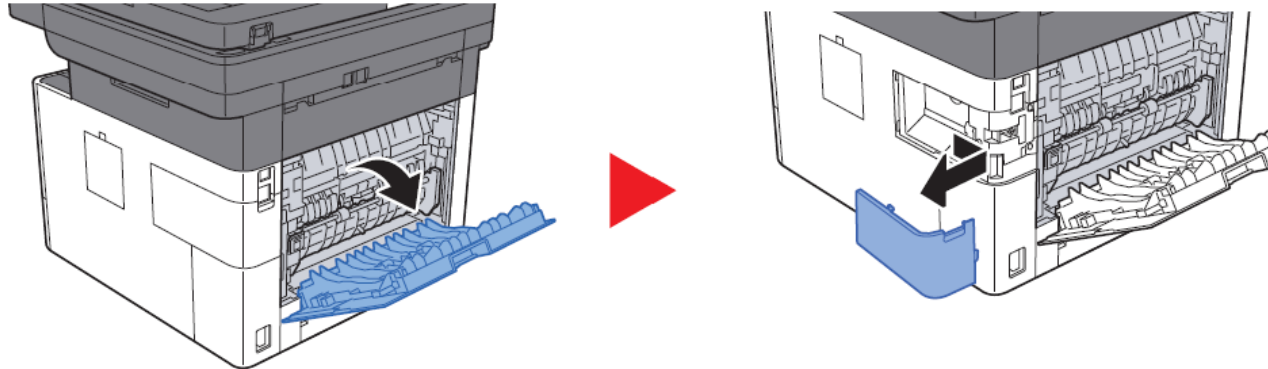

3. Remove the memory module from its package.
4. With the memory connection terminal pointing toward the socket, align the cut-out part with the socket terminal and insert directly in at an angle.

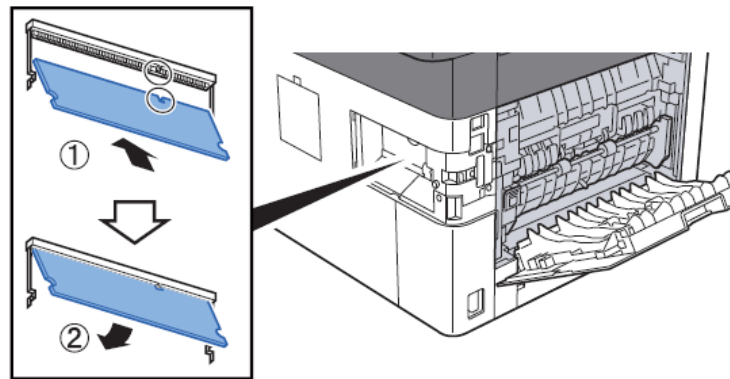

5. Carefully press the inserted memory down and into the machine.
6. Replace the covers.

Installation Environment

1. Temperature: 50 to 90.5°F (10 to 32.5°C) (But humidity should be 70% or less when the temperature is 90.5°F (32.5°C).)
2. Humidity: 10 to 80%(But the temperature should be 86°F (30°C) or less when humidity is 80%.)
3. Power AC100V 50/60Hz 9.7A or more
AC120V 60Hz 8.7A or more
AC220 to 240V 50HzA 4.4A or more
4. Frequency fluctuation: 50Hz+/-2% or 60Hz+/-2%

Installation location

The operative environmental conditions are as follows:

Adverse environmental conditions may affect the image quality. It is recommended to use the machine as follows:
Humidity: 36 to 65% Temperature: 60.8 to 80.6°F or less (16 to 27°C).

Avoid the following locations when selecting a site for the machine.

- Avoid locations near a window or with exposure to direct sunlight
- Avoid locations with vibrations
- Avoid locations with rapid temperature fluctuations
- Avoid locations with direct exposure to hot or cold air
- Avoid poorly ventilated locations

If the floor is delicate, when this machine is moved after installation, the floor material may be damaged by the casters. During operation, some ozone is released, but the amount does not cause any ill effect to one's health. If, however, the machine is used over a long period of time in a poorly ventilated room or when making an extremely large number of copies, the smell may become unpleasant. To maintain the appropriate environment for copy work, it is suggested that the room be properly ventilated.

The configuration of the electrical components

Left side

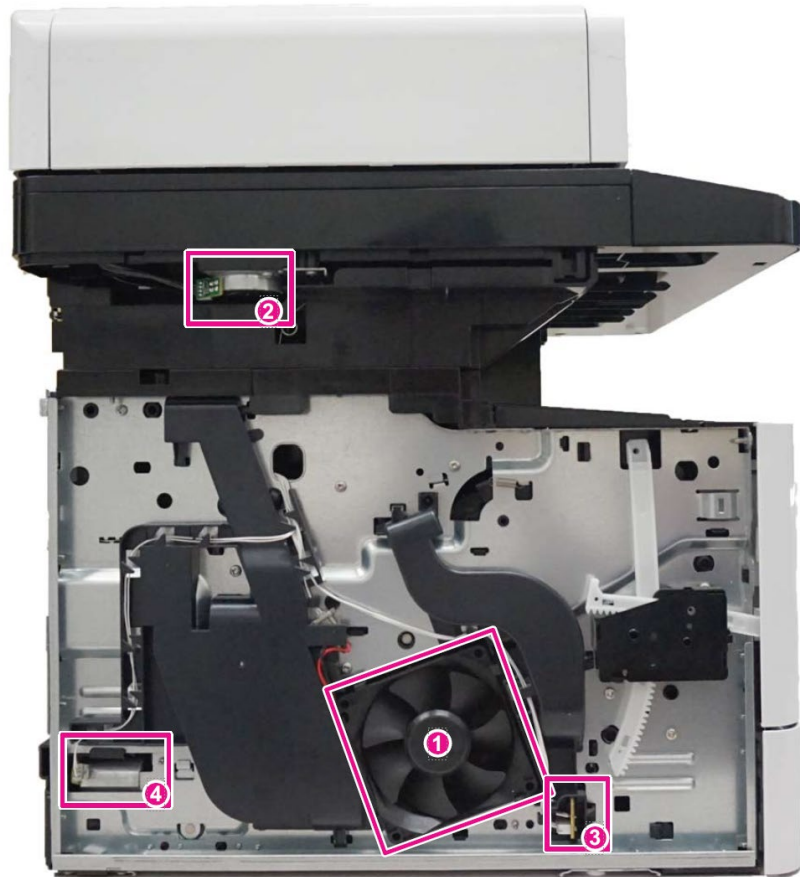

1. Left side fan motor
2. Scanner motor
3. Temp/Humid sensor
4. Fuser pressure release moto

The configuration of the electrical components

Right side

- A. Main/Engine PWB
- B. Power source PWB
- C. Wi-Fi PWB
- 1. Paper feed motor
- 2. Paper feed clutch
- 3. Registration clutch
- 4. Developer clutch
- 5. Right side fan motor
- 6. MP solenoid
- 7. Power switch

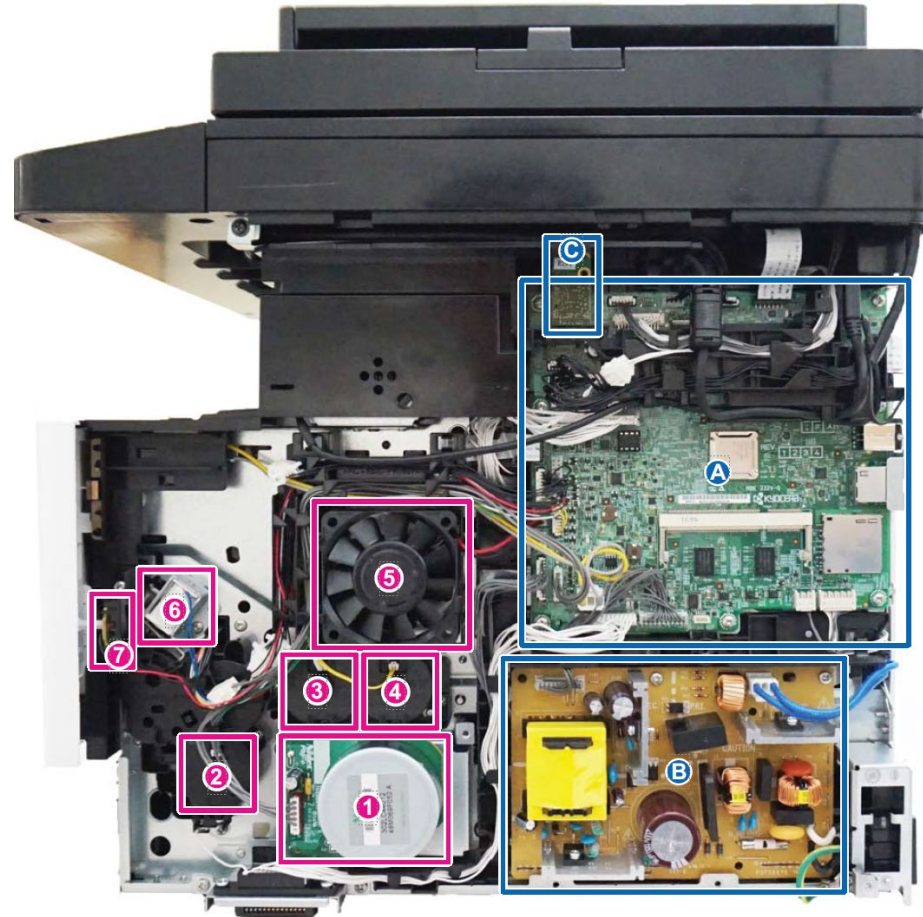

The configuration of the electrical components

Document Processor

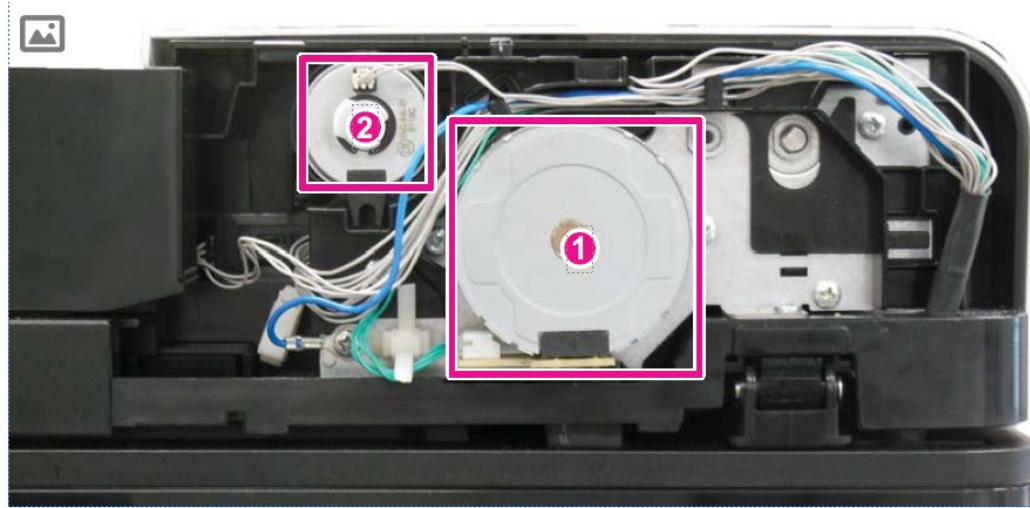

1. PF main PWB
2. PF paper feed clutch

Descriptions about the major PWBs

Main/Engine PWB

Controls the software for interface, image data processing, etc. and hardware for the image scanner, operation unit, high voltage/bias output, paper conveying mechanism, etc.



Descriptions about the major PWBs

High-voltage PWB

Output the main charger high-voltage, the developer bias, the transfer bias, separation bias and the transfer cleaning bias.

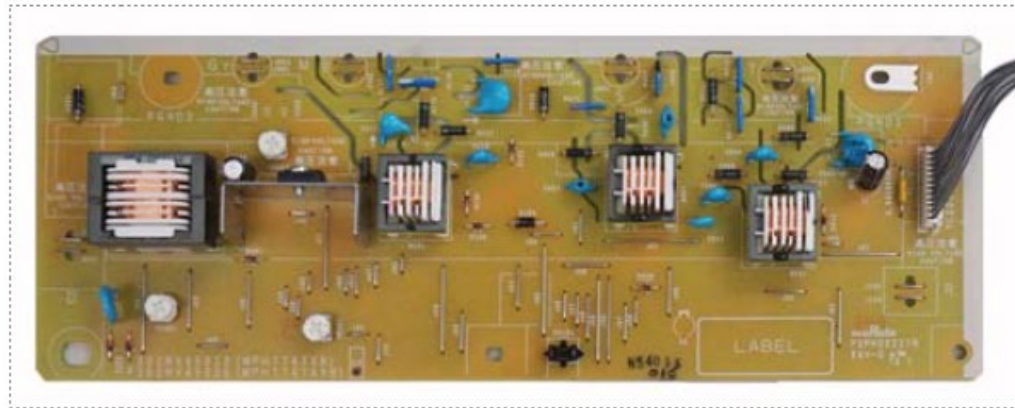

Descriptions about the major PWBs

Power source PWB

The input voltage (AC) from the AC power supply is changed and output to DC such as DC24V. It also controls the fuser heater

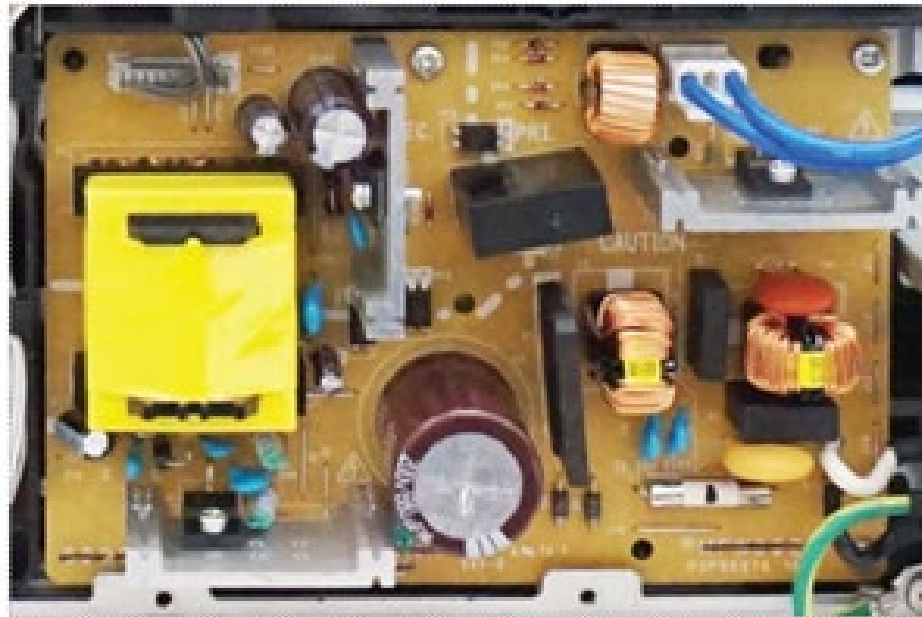

Descriptions about the major PWBs

Operation panel PWB (TSI)

It consists of the relay wiring circuit for the main/engine PWB, the operation key PWB(L/R) and the touch panel.



Descriptions about the major PWBs

Operation panel PWB (LCD)

It consists of the LCD, LED indicators, the key switches.



Electric parts layout

1. FAX PWB *1 Modulate/demodulate of image data, compress/decompress, change resolution and smoothing
2. Main/Engine PWB It controls the software for the interface and image data processing, and controls the hardware such as the image scanner unit, operation section, high voltage/bias output, paper conveying mechanism, etc.
3. Wi-Fi PWB *2 It communicates wireless data.
4. Lower voltage power source PWB The input voltage (AC) from the AC power supply is changed and output to DC such as DC24V. It also controls the fuser heater.
5. Eraser PWB Removing the remaining electric charge on the drum.
6. USB PWB Distribution of USB connector
7. High voltage PWB Output the main charger high-voltage and the developer bias, the transfer bias, separation bias and the transfer cleaning bias.
8. Left key PWB (L) *3 It consists of the LED indicator and the key switches.
9. Operation panel PWB *3 It consists of main/engine PWB, left and right key and the LCD relay wiring circuit.
10. Operation key PWB (R) *3 It consists of the LED indicator and the key switches.
11. Grid PWB Controlling the grid currency
12. APC PWB Emitting and controlling the laser beam.
13. Operation panel PWB *4 It consists of LCD, LED indicators and key switches.
14. PF main PWB Controlling the drive of each electric parts in the PF.

*1: FAX model only, *2: WiFi model only, *3: TSI model only, *4: LCD model only

Laser scanner unit

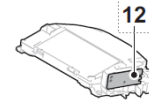

Fuser unit

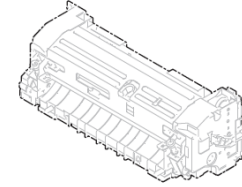

Drum unit

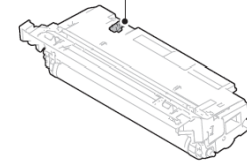

Developer unit

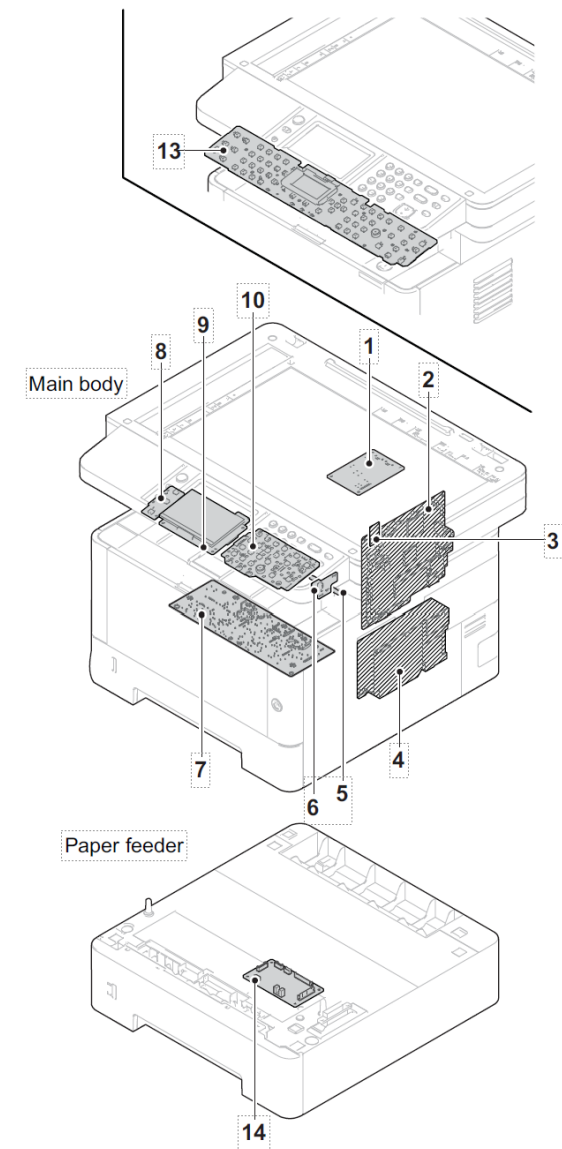
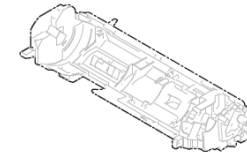

Machine left side / Machine inside / Machine right side

Maintenance parts

(1) Maintenance kits

Maintenance part name		Part No.
Name used in service manual	Name used in parts list	
MK-1150	MK-1150/MAINTENANCE KIT	1702RV0NL0
MK-1151	MK-1151/MAINTENANCE KIT	1702RV0JP0
MK-1152	MK-1152/MAINTENANCE KIT	1702RV0US0
MK-1154	MK-1154/MAINTENANCE KIT	1702RV0AS0
(100,000 image)	DRUM UNIT Developer unit	

(2) Executing the maintenance mode after replacing the maintenance kit

Execute the following maintenance modes after replacing the above maintenance kit.

Section	No.	Maintenance mode
Replacing settings	U130	Developer powder initial setting *1
Maintenance	U251	Maintenance counter clear

*1 Only when replacing the developer unit with the new one.

(3) Maintenance parts list

Maintenance part name		Part No.
Name used in service manual	Name used in parts list	
Pick up roller	PULLEY PICKUP ASSY	302HN0608_
Paper feed roller (Paper feed roller assembly)	PULLEY FEED ASSY (PARTS HOLDER FEED ASSY SP)	302F90623_ (302RV9407_)
MP paper feed roller	ROLLER M/P ASSY	302HS0826_
CONTACT GLASS	PARTS ISU TOP SP	-
Slit glass (ISU upper frame(A4)) (ISU upper frame(Legal))	PARTS ISU TOP SP (PARTS FRAME ISU TOP A ASSY SP) (PARTS FRAME ISU TOP L ASSY SP)	302S01713_ (302S09403_ (302S39401_)

Periodic maintenance Procedures

Check the maintenance counts by the maintenance mode U901

	Parts name	Parts No.	PM maintenance (x1000 counts)			Remark
			Set UP	User Call	100	
			CH AD	CH AD	CH AD	Please do not use spray containing flammable gas for air-blow or air-brush purposes.
1	IMAGE QUALITY	--				
2	MK-1150 MK-1151 MK-1152 MK-1154	1702RV0NL0 1702RV0JPO 1702RV0US0 1702RV0AS0			RE	Drum unit, Developer unit
3	INSIDE OF MACHINE	--		CL	CL	Vacuum: In particular, remove toner and paper dust around imaging and conveying section.
4	PULLEY PICKUP ASSY PULLEY FEED ASSY	302HN06080 302F906230		CL	CL	Alcohol or dry cloth if no replacement.
5	ROLLER M/P ASSY	302HS08260		CL	CL	Alcohol or dry cloth if no replacement.
6	CONTACT GLASS CONTACT-GLASS DP	-- 302S017130		CL CL	CL CL	Dry cloth wiping or Alcohol cleaning.

CH = Check

CL = Clean

AD = Adjust









LU = Lubrication

RE = Replace

Service Manual Layout

Please click on the Active  links alongside each chapter

CONTENTS

- > 1 Specifications 
- > 2 Installation 
- > 3 Machine Design 
- > 4 Maintenance 
- > 5 Firmware 
- > 6 Maintenance mode 
- > 7 Troubleshooting 
- > 8 PWBs 
- > 9 Appendixes 

Service Mode

(1) Executing the maintenance mode

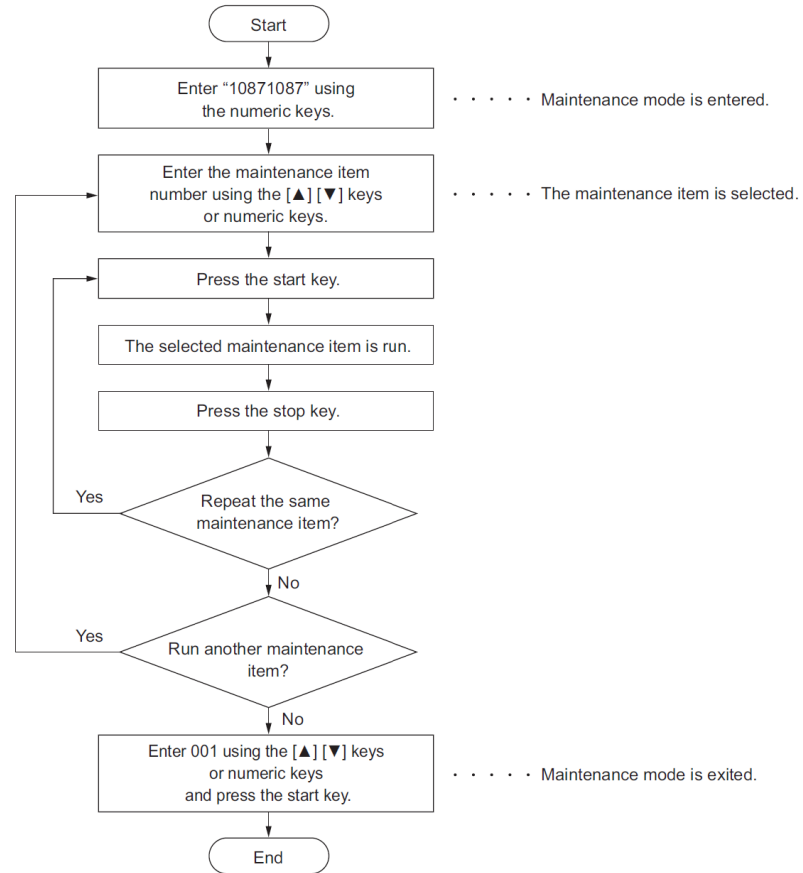

Operational caution

There is a difference of a way of selecting each item by operational section type(TSI or LCD mode).
Read "Select xxx item" in each procedure as follows.

TSI model: Touching the item on the screen and select it.

LCD model: Using the [▲] or [▼] key, select the item.

(In order to move to the adjustment screen, Press the [OK] key or [START] key.)

Troubleshooting Image formation failure

Isolate the place of the image failure occurrence.

<How to isolate the cause>

- Print Test Page to check an image failure.
- [System Menu] > [Adjustment/Maintenance] > [Service Setting]
 - Yes: Engine factor
 - No: Scanner factor
- Check if image failure is enlarged or reduced in the zoom mode.
 - Yes: Scanner factor

1. Scanner factor: Refer to [Image failure at Copy or Send](see page7-2).
(LED lamp for originals on the contact glass --> CIS failure at scanning factor)

Isolate with the original scanning position.

- a. DP surface, on the contact glass (scan by the main unit CIS)
- b. DP back side (scan by DPCIS) (40 ppm model only)

2. Refer to image failure with engine factor (see page 7-36).
(Main charge --> Drum --> LSU --> Developer --> Transfer image formation process failure)

<Image data flow>

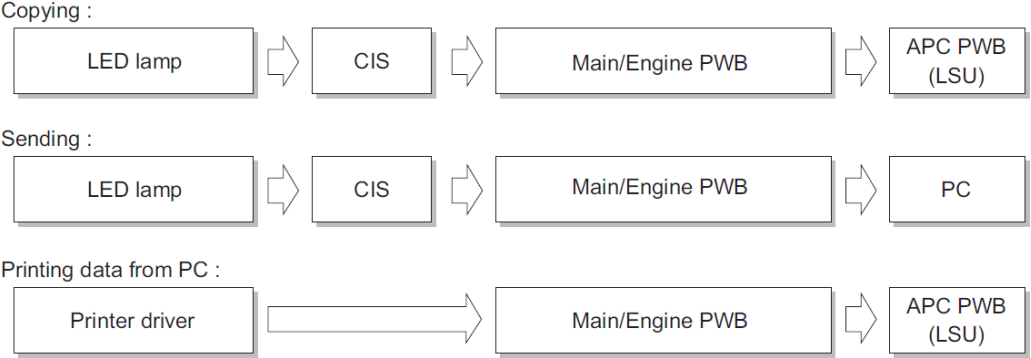

Troubleshooting Image formation failure

Example - Scanner Factors (When scanning the back side through the DP)

(2-3)	Black dots / color dots	
-------	-------------------------	---

(2-3) Black dots / color dots

Target: 40ppm model

Condition: Color dots at transmission only

(When scanning the back side through the DP)

Step	Check description	Assumed cause	Measures	Reference
1	Replacing the original	The original is dirty.	Replace the original.	
2	Replacing the DPCIS	The DPCIS is faulty.	Replace the DPCIS, and then execute U411 [DP FD(ChartA)].	
3	Replacing the main/engine PWB	The main/engine PWB is faulty.	Replace the main/engine PWB.	

Troubleshooting Paper Conveying Failures

(1) Prior standard check items

No.	Contents
(1-1)	Paper jam due to the cover-open detection
(1-2)	Paper jam due to the wave or curl in the fuser section of the damp paper
(1-3)	Paper jam due to the dog-ear, paper skew, paper creases, fusing failure or the paper curl
(1-4)	Paper jam caused by the conveying guide, paper entry guide or the feedshift guide
(1-5)	Paper jam caused by incorrectly loaded paper in the cassette or the paper deck
(1-6)	Paper jam due to the inferior paper
(1-7)	Paper jam caused by the conveying rollers or the paper feed pulleys
(1-8)	Paper jam due to the sensor
(1-9)	Paper jam due to the setting / detection failure
(1-10)	Paper jam due to the static electricity
(1-11)	Paper jam caused by installation in the environment where paper inside the cassette is always moist.

Content of Feeding/Conveying Failures

(1-1) Paper jam due to the cover-open detection





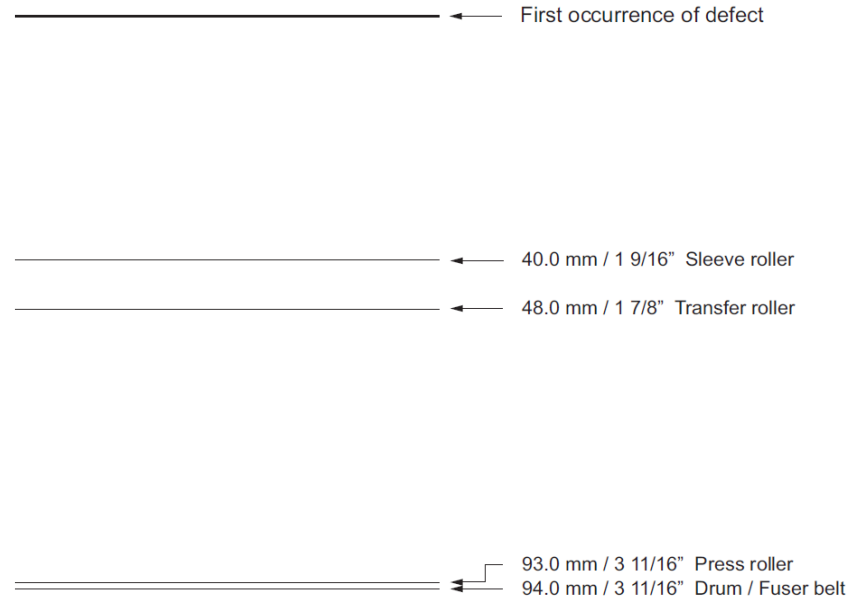

Step	Check description	Assumed cause	Measures	Reference
1	Opening / closing the front cover	The front cover is not engaged.	Open/close the front cover.	
2	Re-loading / replacing paper	The paper fanning is not enough or the cutting edge of loaded paper is damaged.	Fan the paper well and re-load paper after switching top and bottom ends. If the paper is folded, correct or replace it.	
3	Re-loading paper	The paper is wavy.	Correct or replace paper. If difficult to replace, re-load paper by switching top and bottom ends or turning it over.	
4	Checking the paper	Paper out of specification is used or foreign objects adhere to paper.	Ask a user to use the specified paper type. Or, remove the paper with foreign objects.	
5	Re-loading paper	The paper is not properly loaded.	Reload paper in the cassette.	

Troubleshooting using Repetitive defects gauge



*: The repetitive marks interval may vary depending on operating conditions.

Example for Chart of image adjustment procedures

Adjusting order	Item	Image	Maintenance mode		Page	Setting procedure		Remarks
			Item No.	Mode		Method	Setting	
1	Adjusting the center line of the MP tray (printing adjustment)		U034	LSu Out Left	P.6-23	1. Press the [Start] key. 2. Select [Lsu Out Left]. 3. Press the [System Menu] key. 4. Press the [Start] key. (output a test pattern) 5. Press the [System Menu] key. 6. Select [MPT].	1. Press the [◀] [▶] keys or the numeric keys to change the counter value. 2. Press the [Start] key to set the setting value. Press the [Stop] key.	*When the setting value is increased, the image moves leftward. *Adjustment selects [Duplex] at the time of duplex mode.
	Adjusting the LSU print start timing.	(Original: test pattern)						
2	Adjusting the center line of the cassettes (printing adjustment)		U034	LSu Out Left	P.6-23	1. Press the [Start] key. 2. Select [Lsu Out Left]. 3. Press the [System Menu] key. 4. Press the [Start] key. (output a test pattern) 5. Press the [System Menu] key. 6. Select [Cass1] to [Cass3].	1. Press the [◀] [▶] keys or the numeric keys to change the counter value. 2. Press the [Start] key to set the setting value. Press the [Stop] key.	*When the setting value is increased, the image moves leftward. *Adjustment selects [Duplex] at the time of duplex mode.
	Adjusting the LSU print start timing.	(Original: test pattern)						
3	Adjusting the leading edge registration of the MP tray (printing adjustment)		U034	LSu Out Top Full	P.6-23	1. Press the [Start] key. 2. Select [Lsu Out Top Full]. 3. Press the [System Menu] key. 4. Press the [Start] key. (output a test pattern) 5. Press the [System Menu] key. 6. Select [MPT].	1. Press the [◀] [▶] keys or the numeric keys to change the counter value. 2. Press the [Start] key to set the setting value. Press the [Stop] key.	*When the setting value is increased, the image moves downward. *Adjustment selects [Duplex] at the time of duplex mode.
	Changes the secondary feed timing.	(Original: test pattern)						
4	Adjusting the leading edge registration of the cassette (printing adjustment)		U034	LSu Out Top Full	P.6-23	1. Press the [Start] key. 2. Select [Lsu Out Top Full]. 3. Press the [System Menu] key. 4. Press the [Start] key. (output a test pattern) 5. Press the [System Menu] key. 6. Select [Cass].	1. Press the [◀] [▶] keys or the numeric keys to change the counter value. 2. Press the [Start] key to set the setting value. Press the [Stop] key.	*When the setting value is increased, the image moves downward. *Adjustment selects [Duplex] at the time of duplex mode.
	Changes the secondary feed timing.	(Original: test pattern)						
5	Adjusting the leading edge margin (printing adjustment)		U402	Lead	P.6-48	1. Press the [Start] key. 2. Press the [System Menu] key. 3. Press the [Start] key. (output a test pattern) 4. Press the [System Menu] key. 5. Select [Lead].	1. Press the [◀] [▶] keys or the numeric keys to change the counter value. 2. Press the [Start] key to set the setting value. Press the [Stop] key.	*When the setting value is increased, the margin widens.
	Changes the LSU illumination start timing.	(Original: test pattern)						
6	Adjusting the trailing edge margin (printing adjustment)		U402	Trail	P.6-48	1. Press the [Start] key. 2. Press the [System Menu] key. 3. Press the [Start] key. (output a test pattern) 4. Press the [System Menu] key. 5. Select [Trail].	1. Press the [◀] [▶] keys or the numeric keys to change the counter value. 2. Press the [Start] key to set the setting value. Press the [Stop] key.	*When the setting value is increased, the margin widens.
	Changes the LSU illumination end timing.	(Original: test pattern)						





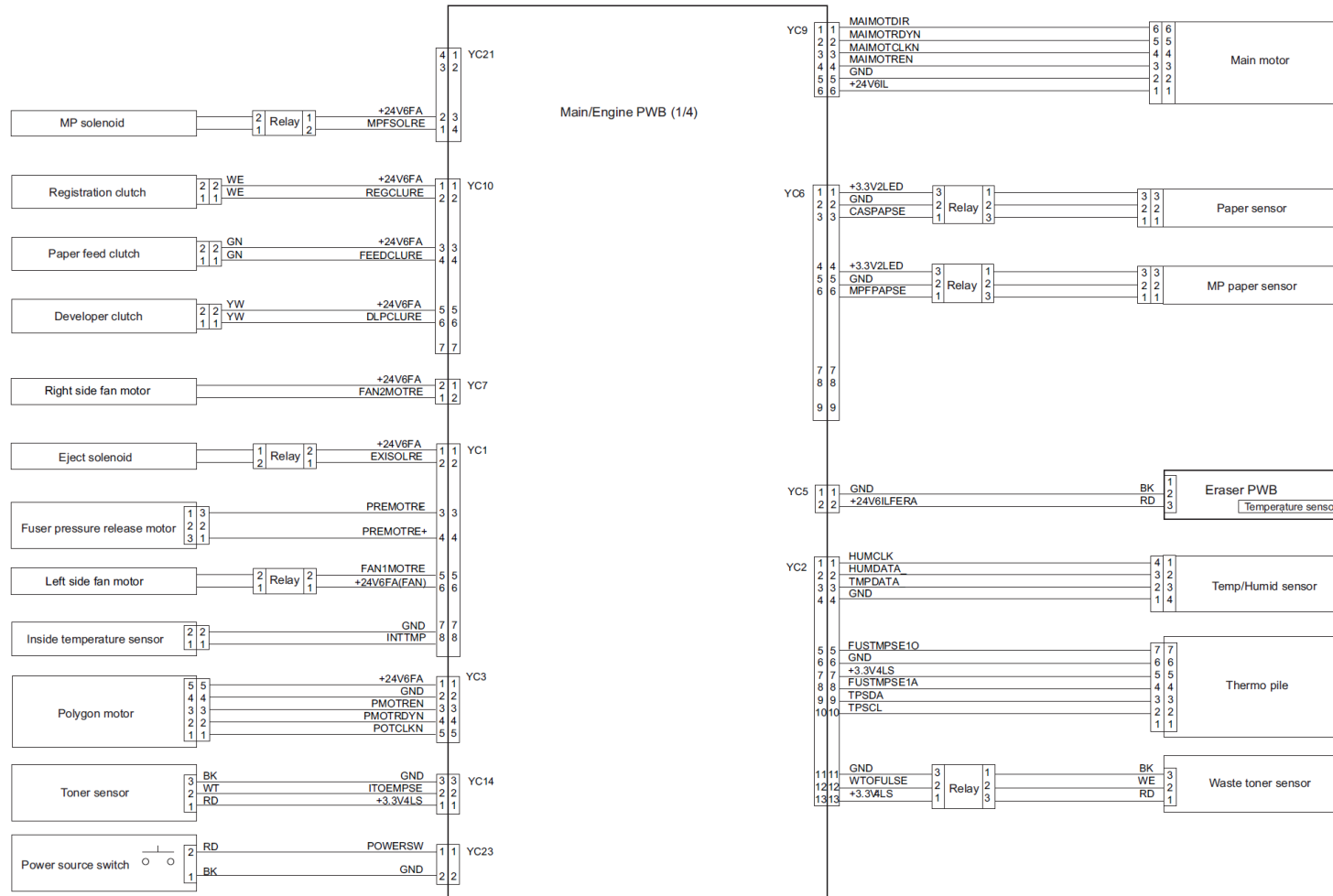









Wiring diagram

(4) Wiring diagram
(4-1) Standard



How to Remove and Replace

Please click on each link to see how to remove and replace below major components

Detaching and Re-attaching	Click on Link
The CIS from Main Unit	
The Developer Section	
The Drum	
The Fuser	
The High Voltage PWB	
The Image Scanner Unit (ISU)	
The Laser Scanner Unit (LSU)	
The Low Voltage Power Source PWB	
The Main and Engine PWB	
The Main Clutches.	
The Main Motor	
The Operation Panel (LCD model)	
The Operation Panel (TSI model)	
The Pickup, Feed and Nudger rollers	
The Transfer Roller Unit	

How To Rebuild The Fuser



[Play](#)

Thank You

Please request the link, from lesliec@soxgp, to complete the assessment to receive your certificate



